

**fluimac**<sup>®</sup>  
p u m p   s o l u t i o n

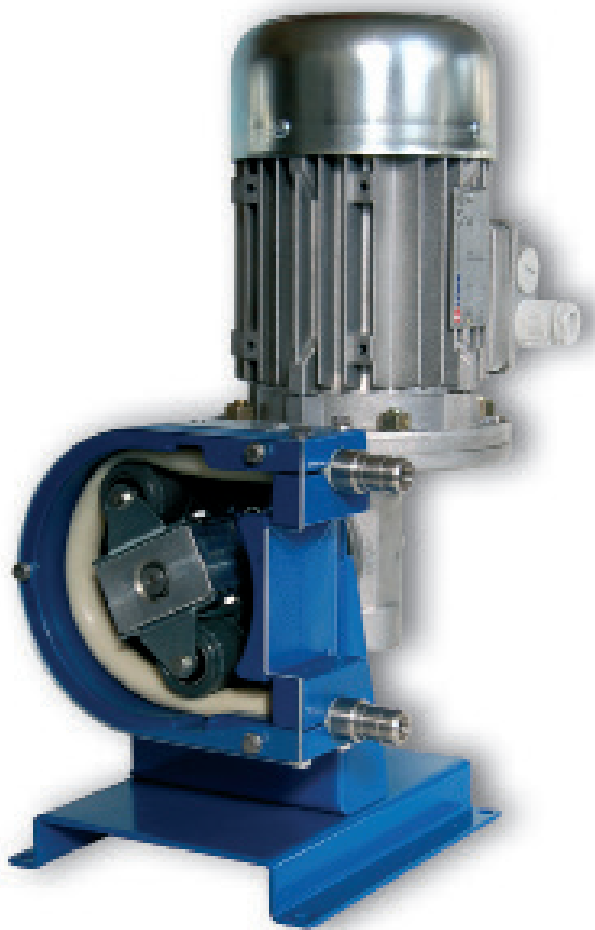

---

**HELIOS**

**HELIOS POMPES PÉRISTALTIQUES**

Made in  
Italy

**TECHNIDOSE**  
Solutions de dosage

FRANÇAIS 



# HELIOS AS

**Pompes de dosage péristaltiques - Basse pression**  
**Capacité jusqu'à environ 2800 l/h- tête de sortie de la pompe jusqu'à 4 bars**  
**Viscosité jusqu'à 15000cps - Aspiration possible jusqu'à 6mts**

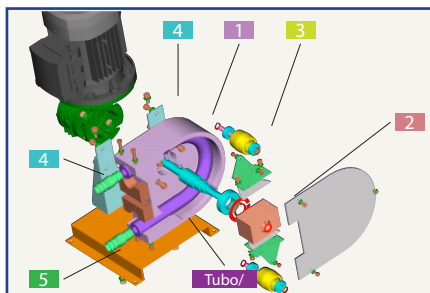

Élément	Matériaux
1 Corps de la pompe	Alliage d'aluminium
2 Rotor	Alliage d'aluminium
3 Rouleaux	PVC
As 25	Alliage d'aluminium
4 Base	Fer
5 Raccord de tuyau	AISI 304

**Couplage spécial:**  
 Raccord de tuyau en AISI 316, PVC, PTFE  
 DIN  
 TRI-CLAMPS  
 ANSI, ISO, UNI, BRIDES

## CARACTÉRISTIQUES TECHNIQUES

- Dosage et refoulement précis et reproductible
- Longue durée et grande fiabilité
- Auto-amorçante
- Fonctionnement à sec continu
- Plus faible coût de possession
- Maintenance simple et rapide

## MATÉRIAUX DE TUYAUX DISPONIBLES:

- NR
- NBR
- Norprène®
- Silicone
- EPDM
- Pharmé®
- Tygon (AS25)
- Hypalon (AS25)



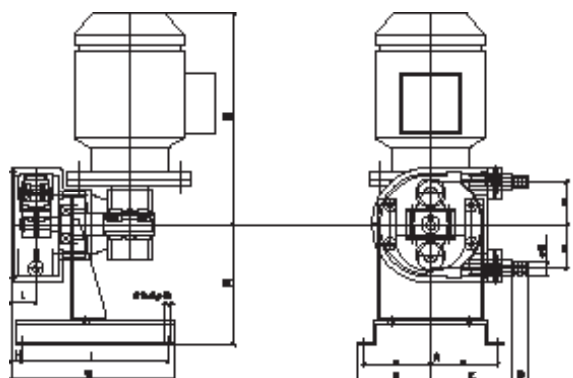

## ENCOMBREMENT

TYPE	A	B	C	D	E	F	G	H	I	L	M	N	øO	Kg.
AS 10 FX	172	92	92	20	15	104	185	12	166	28	137	245	7	9
AS 15 FX	172	92	110	20	20	127	183	12	166	30	137	245	7	10
AS 20 FX	210	112	142	35	25	175	248	18	220	40	184	260	7	18
AS 25 FX	250	146	210	45	32	254	386	81	290	52	228	370	11	40

## CARACTÉRISTIQUES TECHNIQUES

TYPE	Q (L/H)	A	P	RPM	I	KW	di	Qu	Nm
AS 10 FX	23	4	15	23	60	0,18	9	0,017	6
	35	4	15	35	40	0,18			
	47	4	15	47	30	0,18			
	70	4	15	70	20	0,18			
	93	4	15	93	15	0,18			
AS 15 FX	56	4	15	23	60	0,18	13	0,041	12
	86	4	15	35	40	0,18			
	115	4	15	47	30	0,18			
	172	4	15	70	20	0,18			
	228	4	15	93	15	0,18			
AS 20 FX	149	5	* 15 - 40	23	60	0,18	17	0,108	20
	227	5	* 15 - 40	35	40	0,18			
	305	5	* 15 - 30	47	30	0,18			
	453	5	* 15 - 30	70	20	0,18			
	602	5	* 10 - 20	93	15	0,18			
AS 25 FX	538	6	* 20 - 40	28	60	0,37	25	0,320	30
	672	6	* 20 - 40	35	40	0,37			
	902	6	* 20 - 30	47	30	0,37			
	1344	6	* 20 - 30	70	20	0,75			
	1785	6	* 15 - 25	93	15	0,75			

## MOTEUR 3 PH - 230 VOLTS/400 HZ 50 R.P.M. I400 IP55

\*= selon le composé de tuyau

A = Pression d'aspiration en m  
 P = Pression de refoulement en m  
 I = Ratio

di = Diam. Intérieur de Tuyau en mm  
 Qu = Litres par tour  
 Nm = Min. couple de démarrage



DISPONIBLE LA CERTIFICATION ATEX:  
 EX: I M2 & II 2G & IIB, TX

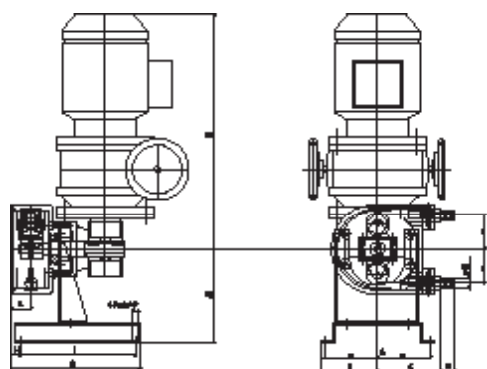

## ENCOMBREMENT

TYPE	A	B	C	D	E	F	G	H	I	L	M	N	øO	Kg.
AS 10 VX	172	92	92	20	15	104	185	12	166	28	137	328	7	12
AS 15 VX	172	92	110	20	20	127	183	12	166	30	137	328	7	13
AS 20 VX	210	112	142	35	25	175	248	18	220	40	184	343	7	22
AS 25 VX	250	146	210	45	32	254	386	81	290	52	228	476	11	45

## CARACTÉRISTIQUES TECHNIQUES

TYPE	Q (L/H)	A	P	RPM	I	KW	di	Qu	Nm
AS 10 VX	3,2 ÷ 15	4	15	3,2 ÷ 15	60	0,22			
	4,7 ÷ 22,5	4	15	4,7 ÷ 22,5	40	0,22			
	6,3 ÷ 30	4	15	6,3 ÷ 30	30	0,22	9	0,017	6
	9,5 ÷ 45	4	15	9,5 ÷ 45	20	0,22			
	19 ÷ 90	4	15	19 ÷ 90	10	0,22			
AS 15 VX	7,8 ÷ 37	4	15	3,2 ÷ 15	60	0,22			
	11,6 ÷ 55	4	15	4,7 ÷ 22,5	40	0,22			
	15,5 ÷ 73,8	4	15	6,3 ÷ 30	30	0,22	13	0,041	12
	23,4 ÷ 110	4	15	9,5 ÷ 45	20	0,22			
	47 ÷ 221	4	15	19 ÷ 90	10	0,22			
AS 20 VX	21 ÷ 97	5	* 15 - 40	3,2 ÷ 15	60	0,22			
	30 ÷ 146	5	* 15 - 40	4,7 ÷ 22,5	40	0,22			
	41 ÷ 194	5	* 15 - 40	6,3 ÷ 30	30	0,22	17	0,108	20
	62 ÷ 291	5	* 15 - 40	9,5 ÷ 45	20	0,22			
	82 ÷ 388	5	* 15 - 40	12,7 ÷ 60	15	0,22			
AS 25 VX	73 ÷ 365	6	* 20 - 40	3,8 ÷ 19	60	0,37			
	90 ÷ 455	6	* 20 - 40	4,7 ÷ 23,7	40	0,37			
	121 ÷ 608	6	* 20 - 35	6,3 ÷ 31,7	30	0,37	25	0,320	30
	182 ÷ 912	6	* 15 - 30	9,5 ÷ 47,5	20	0,37			
	243 ÷ 1280	6	* 15 - 25	12,7 ÷ 66,7	15	0,75			

## MOTEUR 3 PH - 230 VOLTS/400 HZ 50 R.P.M. I400 IP55

\*= selon le composé de tuyau

A = Pression d'aspiration en m  
 P = Pression de refoulement en m  
 I = Ratio

di = Diam. Intérieur de Tuyau en mm  
 Qu = Litres par tour  
 Nm = Min. couple de démarrage

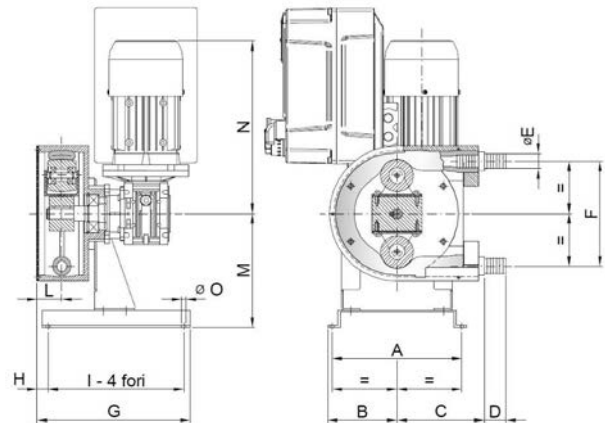

## ENCOMBREMENT

TYPE	A	B	C	D	E	F	G	H	I	L	M	N	øO	Kg.
AS 10 IX	172	92	92	20	15	104	185	12	166	28	137	245	7	9
AS 15 IX	172	92	110	20	20	127	183	12	166	30	137	245	7	10
AS 20 IX	210	112	142	35	25	175	248	18	220	40	184	260	7	18
AS 25 IX	250	146	210	45	32	254	386	81	290	52	228	370	11	40

## CARACTÉRISTIQUES TECHNIQUES

TYPE	Q (L/H)	A	P	RPM	I	KW	di	Qu	Nm
AS 10 IX	1,5 ÷ 47	4	15	1,5 ÷ 47	60	0,18	9	0,017	6
	3 ÷ 93	4	15	3 ÷ 93	30	0,18			
	6 ÷ 185	4	10	6 ÷ 185	15	0,18			
AS 15 IX	3,7 ÷ 115	4	15	1,5 ÷ 47	60	0,18	13	0,041	12
	7 ÷ 172	4	15	2,8 ÷ 70	40	0,18			
	15 ÷ 345	4	15	6 ÷ 140	30	0,18			
AS 20 IX	10 ÷ 304	5	* 15 - 40	1,5 ÷ 47	60	0,18	17	0,108	20
	18 ÷ 453	5	* 15 - 40	2,8 ÷ 70	40	0,18			
	20 ÷ 602	5	* 15 - 30	3 ÷ 93	30	0,18			
AS 25 IX	29 ÷ 902	6	* 20 - 40	1,5 ÷ 47	60	0,37	25	0,320	30
	54 ÷ 1344	6	* 20 - 40	2,8 ÷ 70	40	0,55			
	58 ÷ 1785	6	* 15 - 25	3 ÷ 93	30	0,75			

MOTEUR 3 PH - 230 VOLTS/400 HZ 50 R.P.M. I400 IP55

\*= selon le composé de tuyau

SIGNAL SUR DEMANDE 4-20mA

A = Pression d'aspiration en m  
 P = Pression de refoulement en m  
 I = Ratio

di = Diam. Intérieur de Tuyau en mm  
 Qu = Litres par tour  
 Nm = Min. couple de démarrage



## COURBES DE PERFORMANCE

Débit / Sortie

Q (l/min) Q (l/h)

**AS 10**

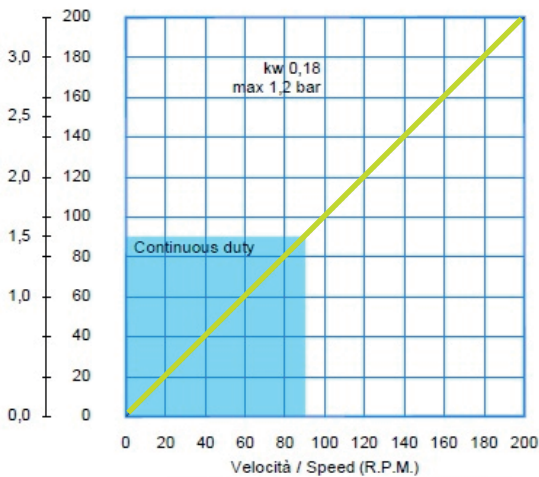

Débit / Sortie

Q (l/min) Q (l/h)

**AS 15**

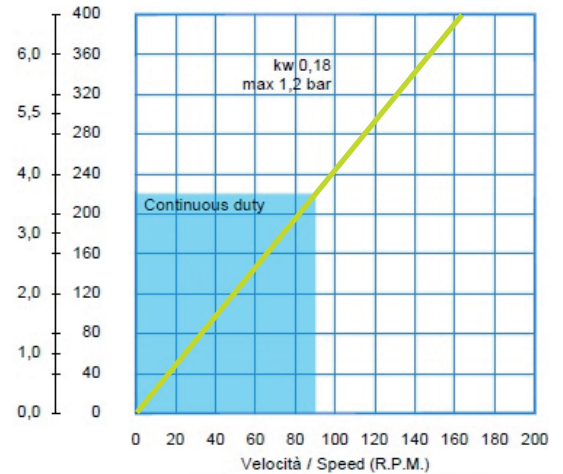

Débit / Sortie

Q (l/min) Q (l/h)

**AS 20**

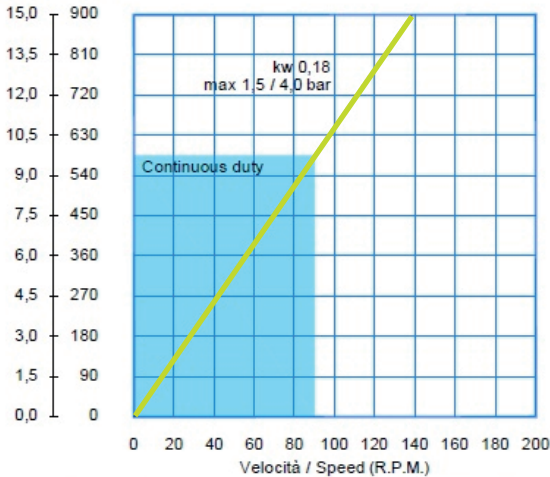

Débit / Sortie

Q (l/min) Q (l/h)

**AS 25**

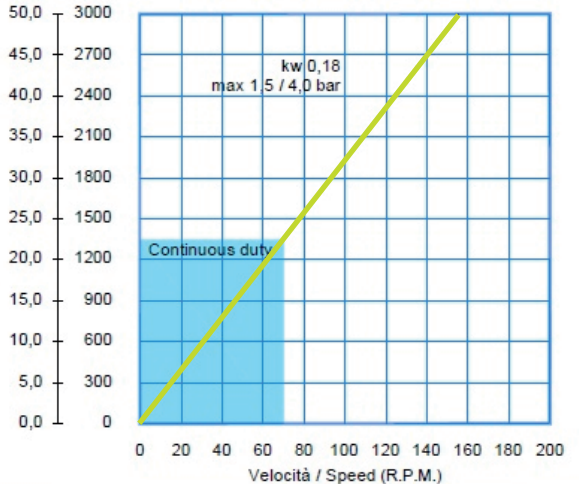

### VERSION SPÉCIALE



DOUBLE TÊTE

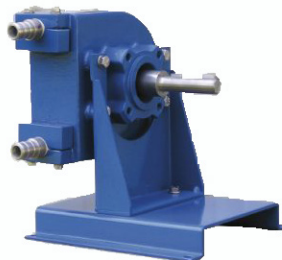

TÊTE  
DE LA POMPE

### UTILISATION DES COURBES

- Le débit requis indique la vitesse de la pompe
- Pression de décharge calculée
- Puissance nette du moteur requise
- Température du fluide
- Vitesse maximale de la pompe requise

Les données de fonctionnement décrites ici se réfèrent à l'eau ou à un fluide de particularité similaire



# HELIOS ASP

**Pompes de dosage péristaltiques**  
 Capacité jusqu'à environ 25000 l/h- tête de sortie de la pompe jusqu'à 10 bars  
 Viscosité jusqu'à 60000cps - Aspiration possible jusqu'à 8mts

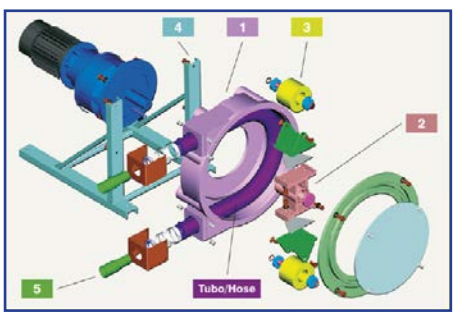

### Élément

- 1 Corps de la pompe
- 2 Rotor
- 3 Rouleaux
- 4 Base
- 5 Raccord de tuyau

### Matériaux

- Alliage d'aluminium
- Alliage d'aluminium
- Aluminium Nylatron
- Fer
- AISI 304

### Couplage spécial:

- Raccord de tuyau en AISI 316, PVC, PTFE
- DIN
- TRI-CLAMPS
- ANSI, ISO, UNI, BRIDES

### CARACTÉRISTIQUES TECHNIQUES

- Absence de joint mécanique et de boîte à garniture
- Robuste
- Adapte aux fluides agressifs et visqueux
- Fonctionnement à sec continue sans dommages
- Pressions de sortie jusqu'à 10 bars
- Entretien très facile

### MATÉRIAUX DE TUYAUX DISPONIBLES:

- NR
- NBR
- EPDM
- NBR pour l'alimentaire
- NR pour l'alimentaire
- Hypalon
- EPDM pour l'alimentaire



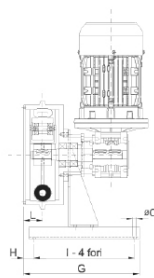

**ASP 10/15**

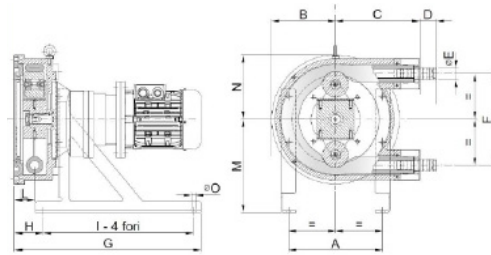
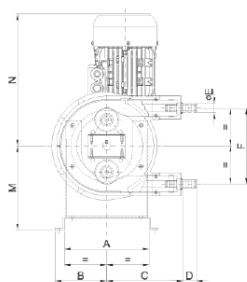

**ASP 25/15 - 25 - 32 - 40 - 50 - 65**

## ENCOMBREMENT

TYPE	A	B	C	D	E	F	G	H	I	L	M	N	øO	Kg.
ASP 10 FX	210	112	166	25	15	167	251	21	220	40	184	260	7	16
ASP 15 FX	210	112	166	30	20	167	251	21	220	40	184	260	7	16
ASP 25/15 FX	250	170	224	25	20	240	495	75	400	52	228	70	11	44
ASP 25 FX	250	170	224	25	32	240	495	75	400	52	228	170	11	44
ASP 32 FX	330	217	230	66	40	314	655	114	520	68	300	217	11	80
ASP 40 FX	420	270	340	70	50	398	735	130	580	74	370	270	14	120
ASP 50 FX	420	330	380	80	65	512	833	158	650	88	440	330	14	160
ASP 65 FX	566	440	510	91	80	672	1107	142	930	106	570	440	17	430

## CARACTÉRISTIQUES TECHNIQUES

TYPE	Q (L/H)	A	P	RPM	I	KW	di	Qu	Nm
ASP 10 FX	47	8	100	23	60	0,18	10	0,034	35
	72	8	80	35	40	0,18			
	96	8	80	47	30	0,37			
	143	8	80	70	20	0,37			
ASP 15 FX	102	8	100	23	60	0,18	15	0,074	35
	155	8	80	35	40	0,18			
	209	8	80	47	30	0,37			
	310	8	80	70	20	0,37			
ASP 25/15 FX	275	8	80	35	40	0,55	15	0,131	40
	354	8	80	45	31,5	0,75			
	440	8	70	56	25	0,75			
	550	8	60	70	20	0,75			
ASP 25 FX	672	8	80	35	40	0,55	25	0,32	40
	864	8	80	45	31,5	0,75			
	1075	8	70	56	25	0,75			
	1344	8	60	70	20	0,75			
ASP 32 FX	1596	8	100	38	37	1,1	32	0,70	75
	1974	8	80	47	30	1,1			
	2436	8	60	58	24	1,1			
	2940	8	40	70	20	1,1			
ASP 40 FX	2040	8	100	25	56	1,5	40	1,36	110
	2938	8	80	36	39	1,5			
	3672	8	60	45	31,5	1,5			
	5712	8	40	70	20	1,5			
ASP 50 FX	4185	8	100	25	56	2,2	50	2,79	200
	6026	8	60	36	39	2,2			
	7533	8	60	45	31,5	3			
	11718	8	40	70	20	3			
ASP 65 FX	8580	8	80	22	63	4	65	6,50	400
	13650	8	60	35	40	5,5			
	15500	8	60	45	31,5	7,5			
	21840	8	50	56	25	7,5			

## MOTEUR 3 PH - 230 VOLTS/400 HZ 50 R.P.M. I400 IP55

\*= selon le composé de tuyau

A = Pression d'aspiration en m

di = Diam. Intérieur de Tuyau en mm

P = Pression de refoulement en m

Qu = Litres par tour

I = Ratio

Nm = Min. couple de démarrage



DISPONIBLE LA CERTIFICATION ATEX:

EX: I M2 & II 2G & IIB, TX



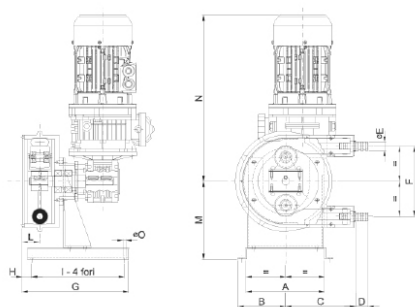

**ASP 10/15**

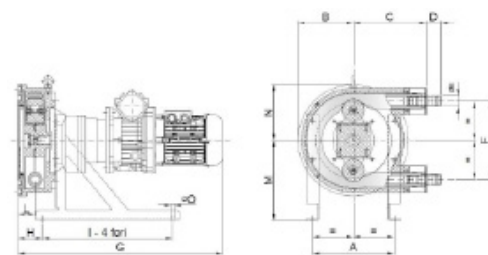

**ASP 25/15 - 25 - 32 - 40 - 50 - 65**

## ENCOMBREMENT

TYPE	A	B	C	D	E	F	G	H	I	L	M	N	øO	Kg.
<b>ASP 10 VX</b>	210	112	166	25	15	167	251	21	220	40	184	345	7	20
<b>ASP 15 VX</b>	210	112	166	30	20	167	251	21	220	40	184	345	7	20
<b>ASP 25/15 VX</b>	250	170	224	45	20	240	640	75	400	52	228	170	11	50
<b>ASP 25 VX</b>	250	170	224	45	32	240	640	75	400	52	228	170	11	50
<b>ASP 32 VX</b>	330	217	290	66	40	314	735	114	520	68	300	217	11	90
<b>ASP 40 VX</b>	420	270	340	70	50	398	884	130	580	74	370	270	14	120
<b>ASP 50 VX</b>	420	330	380	80	65	512	1017	158	650	88	440	330	14	180
<b>ASP 65 VX</b>	566	440	510	91	80	672	1385	142	930	106	570	440	18	430

## CARACTÉRISTIQUES TECHNIQUES

TYPE	Q (L/H)	A	P	RPM	I	KW	di	Qu	Nm
<b>ASP 10 VX</b>	6,5÷30,6	8	100/80	3,2÷15	60	0,22	10	0,034	35
	9,6÷46	8	100/70	4,7÷22,5	40	0,22			
	15,5÷77,5	8	100/60	7,6÷38	25	0,37			
	26÷129	8	100/50	12,7÷63,3	15	0,37			
<b>ASP 15 VX</b>	14,2÷66,6	8	100/80	3,2÷15	60	0,22	15	0,074	35
	21÷100	8	100/70	4,7÷22,5	40	0,22			
	34÷168,7	8	100/60	7,6÷38	25	0,37			
	56,4÷281	8	100/50	12,7÷63,3	15	0,37			
<b>ASP 25/15 VX</b>	37÷196,5	8	100/60	4,7÷25	40	0,55	15	0,131	40
	60÷314,4	8	100/70	7,6÷40	25	0,75			
	94,3÷487,3	8	100/50	12÷62	16	0,75			
	118÷629	8	100/40	15÷80	12,5	0,75			
<b>ASP 25 VX</b>	90÷480	8	100/60	4,7÷25	40	0,55	25	0,32	40
	146÷768	8	100/60	7,6÷40	25	0,75			
	230÷1190	8	100/50	12÷62	16	0,75			
	288÷1536	8	100/40	15÷80	12,5	0,75			
<b>ASP 32 VX</b>	210÷1134	8	100/60	5÷27	37	1,1	32	0,70	75
	319÷1680	8	100/60	7,6÷40	25	1,1			
	504÷2604	8	100/50	12÷62	16	1,1			
	630÷3360	8	100/40	15÷80	12,5	1,1			
<b>ASP 40 VX</b>	342÷1811	8	100/60	4,2÷22,2	45	1,5	40	1,36	110
	489÷2611	8	100/60	6÷32	31,5	1,5			
	775÷4080	8	100/50	9,5÷50	20	2,2			
	979÷5059	8	100/40	12÷62	16	2,2			
<b>ASP 50 VX</b>	703÷3716	8	100/60	4,2÷22,2	45	2,2	50	2,79	200
	1004÷5356	8	100/60	6÷32	31,5	2,2			
	1590÷8370	8	100/50	9,5÷50	20	3			
	2008÷10378	8	100/40	12÷62	16	3			
<b>ASP 65 VX</b>	1638÷8658	8	100/60	4,2÷22,2	45	4	65	6,50	400
	2340÷12480	8	100/60	6÷32	31,5	5,5			
	2964÷15600	8	100/50	7,6÷40	25	7,5			
	3705÷19500	8	100/40	9,5÷50	20	7,5			

## MOTEUR 3 PH - 230 VOLTS/400 HZ 50 R.P.M. I400 IP55

\*= selon le composé de tuyau

A = Pression d'aspiration en m

di = Diam. Intérieur de Tuyau en mm

P = Pression de refoulement en m

Qu = Litres par tour

I = Ratio

Nm = Min. couple de démarrage

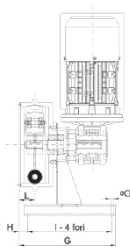

**ASP 10/15**

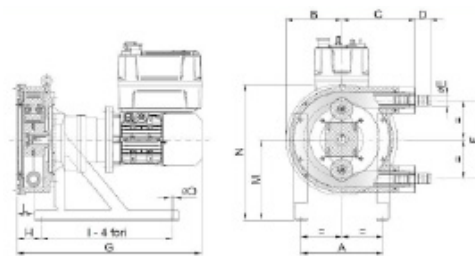
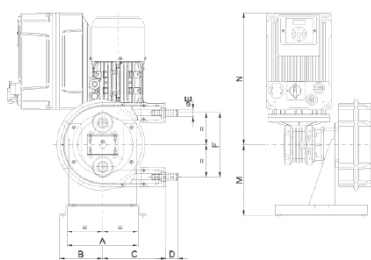

**ASP 25/15 - 25 - 32 - 40 - 50 - 65**

## ENCOMBREMENT

TYPE	A	B	C	D	E	F	G	H	I	L	M	N	øO	Kg.
ASP 10 IX	210	112	166	25	15	167	251	21	220	40	184	334	7	25
ASP 15 IX	210	112	166	30	20	167	251	21	220	40	184	334	7	25
ASP 25/15 IX	250	170	224	25	20	240	550	75	400	52	228	398	11	54
ASP 25 IX	250	170	224	25	32	240	550	75	400	52	228	398	11	54
ASP 32 IX	330	217	230	66	40	314	654	114	520	68	300	517	11	90
ASP 40 IX	420	270	340	70	50	398	735	130	580	74	370	640	14	130
ASP 50 IX	420	330	380	80	65	512	833	158	650	88	440	770	14	170
ASP 65 IX	566	440	510	91	80	672	1107	142	930	106	570	1010	18	430

## CARACTÉRISTIQUES TECHNIQUES

TYPE	Q (L/H)	A	P	RPM	I	KW	di	Qu	Nm
ASP 10 IX	9÷65	8	100/80	4,5÷32	60	0,25	10	0,034	35
	19÷130	8	100/60	9,3÷65	40	0,37			
	28,5÷200	8	100/50	14÷98	20	0,37			
ASP 15 IX	20÷142	8	100/80	4,5÷32	60	0,25	15	0,074	35
	41,3÷289	8	100/60	9,3÷65	30	0,37			
	62÷435	8	100/50	14÷98	20	0,37			
ASP 25/15 IX	55÷385	8	100/80	7÷49	40	0,75	15	0,131	40
	71÷495	8	100/60	9÷63	31,5	0,75			
	110÷870	8	100/50	14÷98	20	0,75			
ASP 25 IX	134÷940	8	100/80	7÷49	40	0,75	25	0,32	40
	173÷1210	8	100/60	9÷63	31,5	0,75			
	268÷1880	8	100/50	14÷98	20	0,75			
ASP 32 IX	294÷2058	8	100/80	7÷49	46	1,5	32	0,70	75
	390÷2730	8	100/50	9,3÷65	30	1,5			
	588÷4116	8	100/40	14÷98	20	1,5			
ASP 40 IX	408÷2856	8	100/80	5÷35	56	1,5	40	1,36	110
	734÷5140	8	100/50	9÷63	31,5	2,2			
	938÷6528	8	100/40	11,5÷80	24,5	2,2			
ASP 50 IX	837÷5860	8	100/80	5÷35	56	2,2	50	2,79	200
	1507 ÷10546	8	100/50	9÷63	31,5	3			
	1925÷13395	8	100/40	11,5÷80	24,5	4			
ASP 65 IX	1720÷12090	8	100/80	4,4÷31	63	7,5	65	6,50	400
	2730÷19110	8	100/50	7÷49	40	7,5			
	3510÷24570	8	100/40	9÷63	31,5	7,5			

MOTEUR 3 PH - 230 VOLTS/400 HZ 50 R.P.M. I400 IP55

\*= selon le composé de tuyau

SIGNAL SUR DEMANDE 4-20mA

A = Pression d'aspiration en m  
P = Pression de refoulement en m  
I = Ratio

di = Diam. Intérieur de Tuyau en mm  
Qu = Litres par tour  
Nm = Min. couple de démarrage

## COURBES DE PERFORMANCE

ASP 10

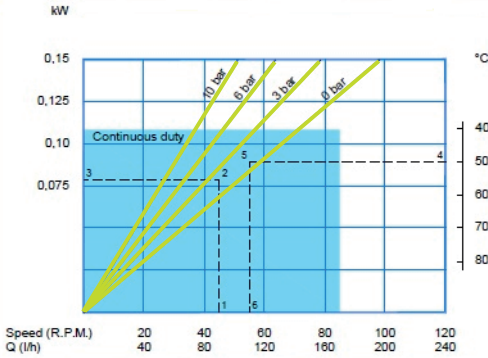

ASP 15

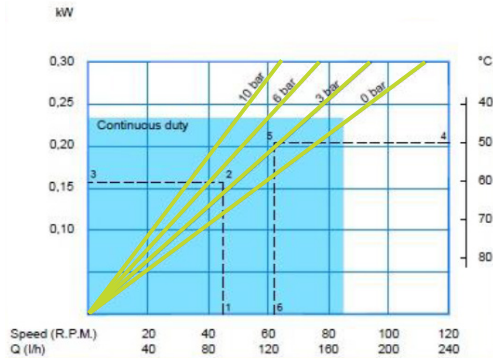

ASP 25/15

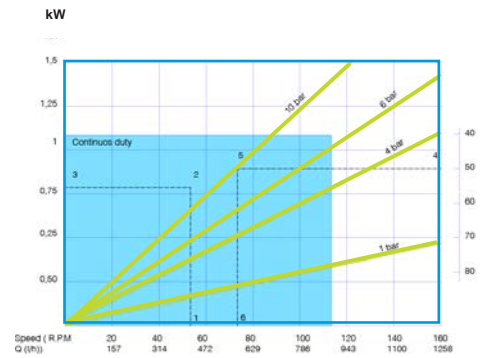

ASP 25

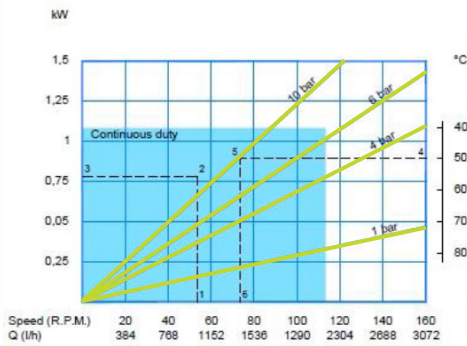

ASP 32

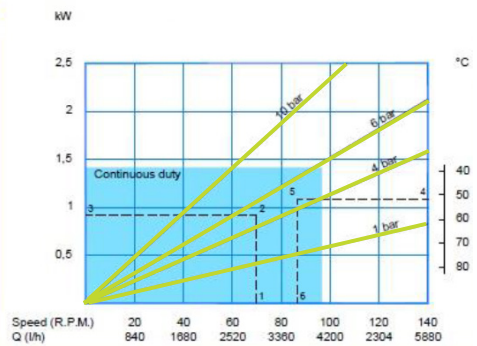

ASP 40

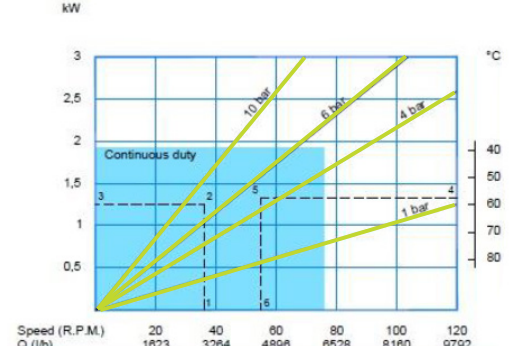

ASP 50

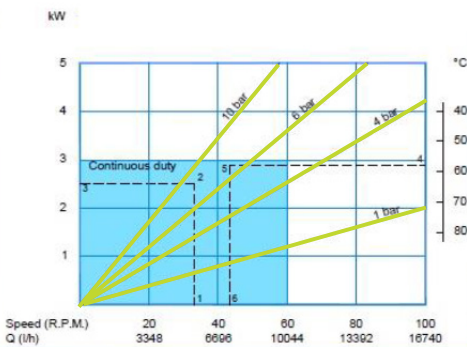

ASP 65

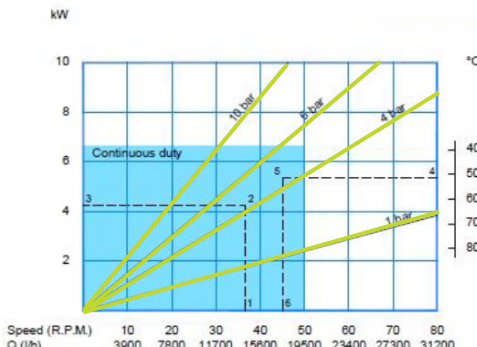

### UTILISATION DES COURBES

- Le débit requis indique la vitesse de la pompe
- Pression de décharge calculée
- Puissance nette du moteur requise
- Température du fluide
- Vitesse maximale de la pompe requise

Les données de fonctionnement décrites ici se réfèrent à l'eau ou à un fluide de particularité similaire

### VERSION SPÉCIALE



DOUBLE TÊTE



TÊTE DE LA POMPE



CHARIOT

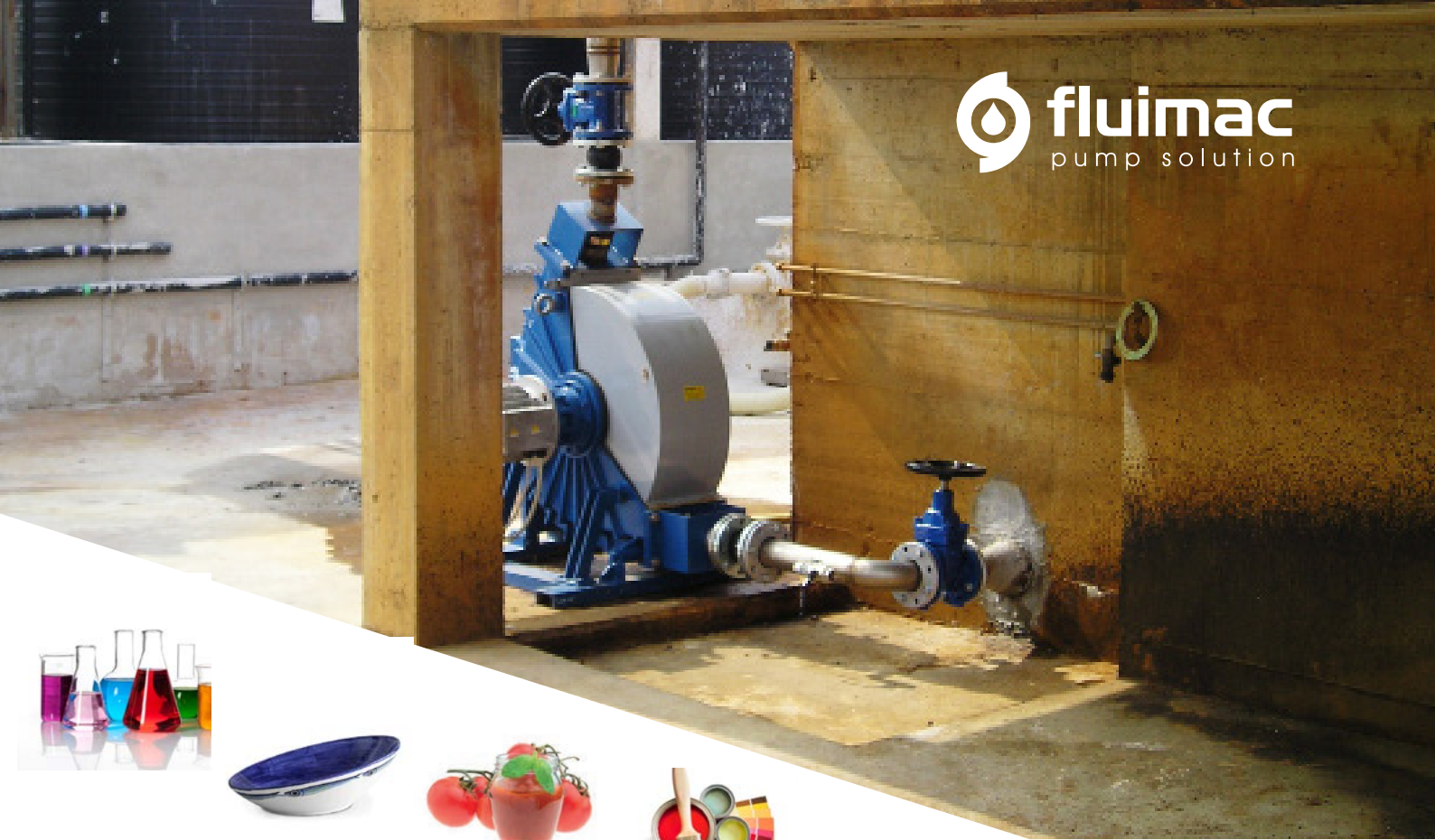

# HELIOS ATR

Pompes de dosage péristaltiques

Capacité jusqu'à environ 64000 l/h- tête de sortie de la pompe jusqu'à 8 bars

Viscosité jusqu'à 60000cps - Aspiration possible jusqu'à 8mts

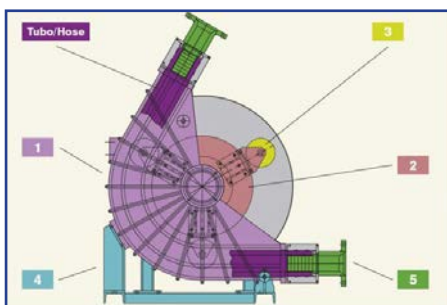

## Élément

- 1 Corps de la pompe
- 2 Rotor
- 3 Rouleaux
- 4 Base
- 5 Brides ISO

## Matériaux

- Fonte
- Fer
- Aluminium Nylatron
- Fer
- AISI 304

### Couplage spécial:

- DIN
- TRI-CLAMPS
- ANSI, ISO, UNI, BRIDES

## CARACTÉRISTIQUES TECHNIQUES

- Absence de joint mécanique et de boîte à garniture
- Robuste
- Adapte aux fluides agressifs et visqueux
- Fonctionnement à sec continue sans dommages
- Pressions de sortie jusqu'à 8 bars
- Entretien très facile
- Grande prestation

## MATÉRIAUX DE TUYAUX DISPONIBLES

- NR
- NBR
- EPDM
- NR pour l'alimentaire
- Hypalon





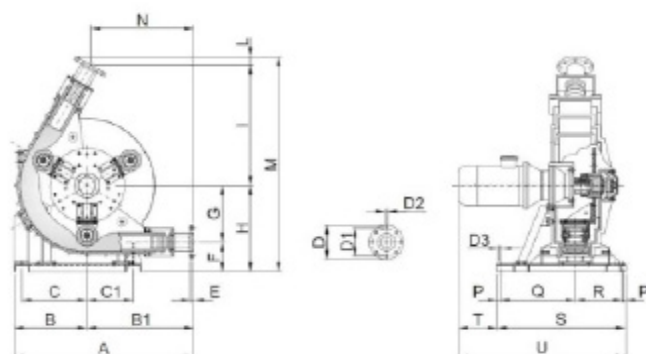

## ATR 80 FX/TD

### ENCOMBREMENT

A	B	B1	C	C1	D	D1	D2	D3	E	F	G	H	I	L	M	N	O	P	Q	R	S	T	U
1148	467	681	417	295	220	180	16	18	22	189	365	554	772	55	1391	657	O	20	480	300	820	245	1065

### CARACTÉRISTIQUES TECHNIQUES

Q(L/H)	A	P	RPM	Kw	di	Qu	Nm	Kg
12160	8	50 (80)	22,3	5,5 (7,5)				
18874	8	30 (50)	34,6	5,5 (9)	80	9,1	1200	390
21915	8	25 (45)	40,1	5,5 (9)				
26422	8	20 (40)	48,4	7,5 (11)				

## ATR 280 FX/TD

### ENCOMBREMENT

A	B	B1	C	C1	D	D1	D2	D3	E	F	G	H	I	L	M	N	O	P	Q	R	S	T	U
1148	467	681	417	295	220	180	16	18	22	189	365	554	772	55	1391	657	119	20	550	370	960	294	1254

### CARACTÉRISTIQUES TECHNIQUES

Q(L/H)	A	P	RPM	Kw	di	Qu	Nm	Kg
24321	8	50 (80)	22,2	7,5 (11)				
37748	8	30 (50)	34,6	11 (15)	80	18,2	2000	515
43830	8	25 (45)	40,1	11 (15)				
52845	8	20 (40)	48,4	11 (15)				

### MOTEUR 3 PH - 230 VOLTS/400 HZ 50 R.P.M. I400 IP55

\* = selon le composé de tuyau  
 A = Pression d'aspiration en m  
 P = Pression de refoulement en m

di = Diam. Intérieur de Tuyau en mm  
 Qu = Litres par tour  
 Nm = Min. couple de démarrage

**Ex** DISPONIBLE LA CERTIFICATION ATEX:  
 EX: I M2 & II 2G & IIB, TX



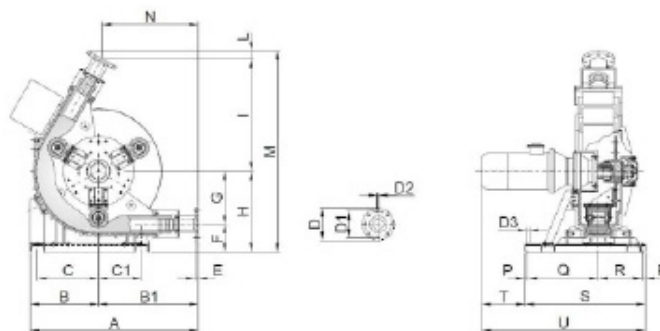

## ATR 80 IX/TD

### ENCOMBREMENT

A	B	B1	C	C1	D	D1	D2	D3	E	F	G	H	I	L	M	N	O	P	Q	R	S	T	U
1148	467	681	417	295	220	180	16	18	22	189	365	554	772	55	1381	657	O	20	480	300	820	245	1065

### CARACTÉRISTIQUES TECHNIQUES

Q(L/H)	A	P	RPM	Kw	hz	di	Qu	Nm	Kg
2432 ÷ 14592	8	50 (80)	4,5 ÷ 26,7	5,5 (7,5)					
3775 ÷ 22649	8	30 (50)	6,9 ÷ 41,5	5,5 (9)	10 ÷ 60	80	9,1	1200	440
4383 ÷ 26298	8	25 (45)	8,0 ÷ 48,2	7,5 (11)					
5284 ÷ 31707	8	20 (40)	9,7 ÷ 58,1	7,5 (11)					

## ATR 280 IX/TD

### ENCOMBREMENT

A	B	B1	C	C1	D	D1	D2	D3	E	F	G	H	I	L	M	N	O	P	Q	R	S	T	U
1148	467	681	417	295	220	180	16	18	22	189	365	554	772	55	1381	657	119	20	550	370	960	294	1254

### CARACTÉRISTIQUES TECHNIQUES

Q(L/H)	A	P	RPM	Kw	hz	di	Qu	Nm	Kg
4864 ÷ 29185	8	50 (80)	4,5 ÷ 26,7	11 (15)					
7550 ÷ 45298	8	30 (50)	6,9 ÷ 41,5	11 (15)	10 ÷ 60	80	18,2	2000	580
8766 ÷ 52596	8	25 (45)	8,0 ÷ 48,2	11 (15)					
10569 ÷ 63414	8	20 (40)	9,7 ÷ 58,1	11 (15)					

### MOTEUR 3 PH - 230 VOLTS/400 HZ 50 R.P.M. I400 IP55

#### SIGNAL SUR DEMANDE 4-20mA

\* = selon le composé de tuyau  
 A = Pression d'aspiration en m  
 P = Pression de refoulement en m

di = Diam. Intérieur de Tuyau en mm  
 Qu = Litres par tour  
 Nm = Min. couple de démarrage

## COURBES DE PERFORMANCE

## VERSION SPÉCIALE

Débit / Sortie

**ATR 80**

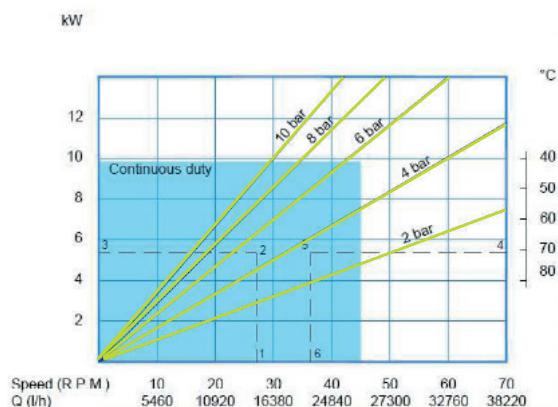

Débit / Sortie

**ATR 280**

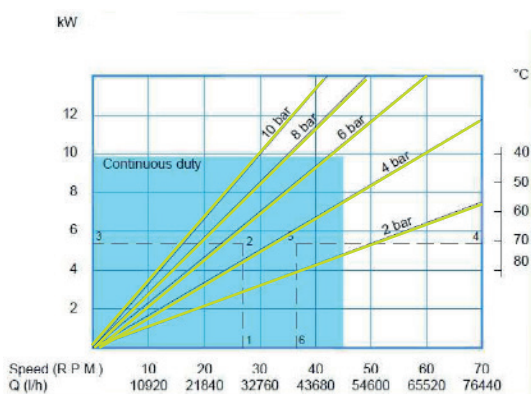

### UTILISATION DES COURBES

- Le débit requis indique la vitesse de la pompe
- Pression de décharge calculée
- Puissance nette du moteur requise
- Température du fluide
- Vitesse maximale de la pompe requise

Les données de fonctionnement décrites ici se réfèrent à l'eau ou à un fluide de particularité similaire



**ATR 80/280 TC**  
TRANSMISSION PAR COURROIE



TÊTE DE LA POMPE



CHARIOT

# fluimac®

pump solution



**FLUIMAC S.r.l.**

Via Brescia 1  
21049, Tradate (VA) - Italy  
Tel.:+39 0331 866688  
Fax:+39 0331 864870

[www.fluimac.com](http://www.fluimac.com)  
[info@fluimac.com](mailto:info@fluimac.com)

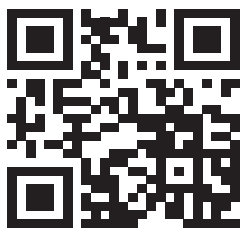

**PARTENAIRE AUTORISÉ:**

# TECHNIDOSE

Solutions de dosage

*Made in Italy*

